

Check valve with inspection plug Type 2290

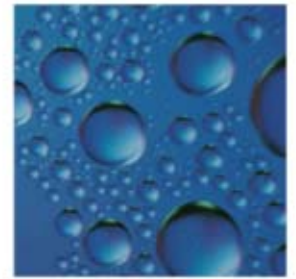

Version 01_06



Type 2290 Check valve with inspection plug

Application:

Designed for use in cold and hot water supply systems, central and district heating plants and air.

Test:

JCH's 100% test, and 1 yearly external audit test, carried out by danish institute of technology

Material

Body:	DZR brass CW602N
Cartridge:	Watts Ocean type IN:POM
O-ring:	NBR Rubber
Inspections plug:	DZR brass CW602N
Gasket plug:	PTFE seal

Check valve with inspection plug Type 2290

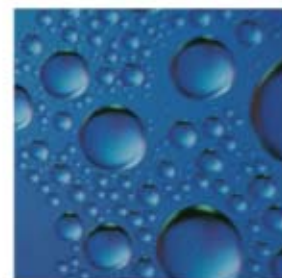

Version 01_06

Type 2290 Type 90 og 94 has a very low opening pressure of 100mmWC.

Working pressure: 10 bar, test pressure: 16 bar.

Max. temperature: 90° C

produced to meet the EU EN1717 standard

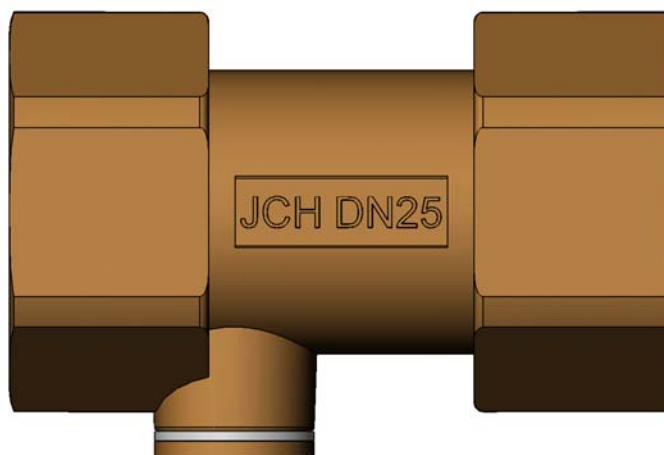

Order No..	DN mm	L lenght mm	NV mm	RG	weight Kg
2290-003	10	51	22	3/8"	0,099
2290-004	15	57	27	1/2"	0,159
2290-006	20	65	30	3/4"	0,189
2290-008	25	75	41	1"	0,386
2290-010	32	85	50	1.1/4"	0,637
2290-011	40	92	56	1.1/2"	0,753
2290-012	50	112	68	2"	1,222

J.C.HANSENS METALVAREFABRIK ApS

Karetmagervej 21 | DK-7100 Vejle | Tel. +45 75 85 84 08 | Fax +45 75 85 80 82
jchansen@jchansen.dk | www.jchansen.dk