

Regulation valve Type 10 og 11

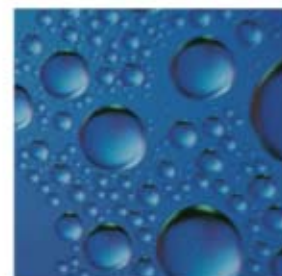

Version 01_06



Regulation valve Type 10 og 11

Application:

all types of heating plants with water or low pressure steam

Test:

all valves has passed JCH's 100% test

Additional parts:

spareparts

Material

Cover with scale:	Plastic
Screw for handwheel:	electroplated screw
Handwheel:	Plastic
Sprocket:	Plastic
Indication ring:	Plastic
Body:	DZF brass CW602N
Screw for cover:	Electroplated screw
cover for O-ring:	Plastic
O-ring:	EPDM rubber
packing:	Teflon PTFE
Bonnet:	DZF brass CW602N
Spring:	Steel
Regulation palette:	MONEL
Seat sealing:	Teflon PTFE

Regulation valve Type 10 og 11

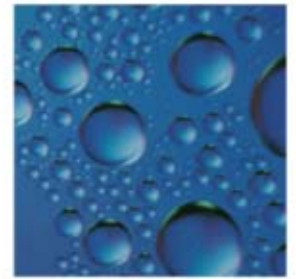

Version 01_06

Regulation valve made of DZF brass
 Working temperature: 100° C
 Max. Temperature: 120° C
 Working pressure: 10 bar
 Test pressure: 16 bar

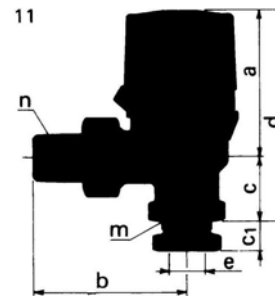
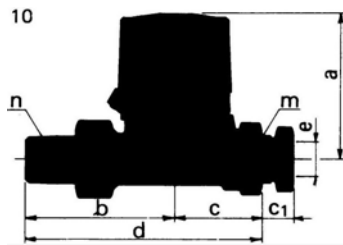
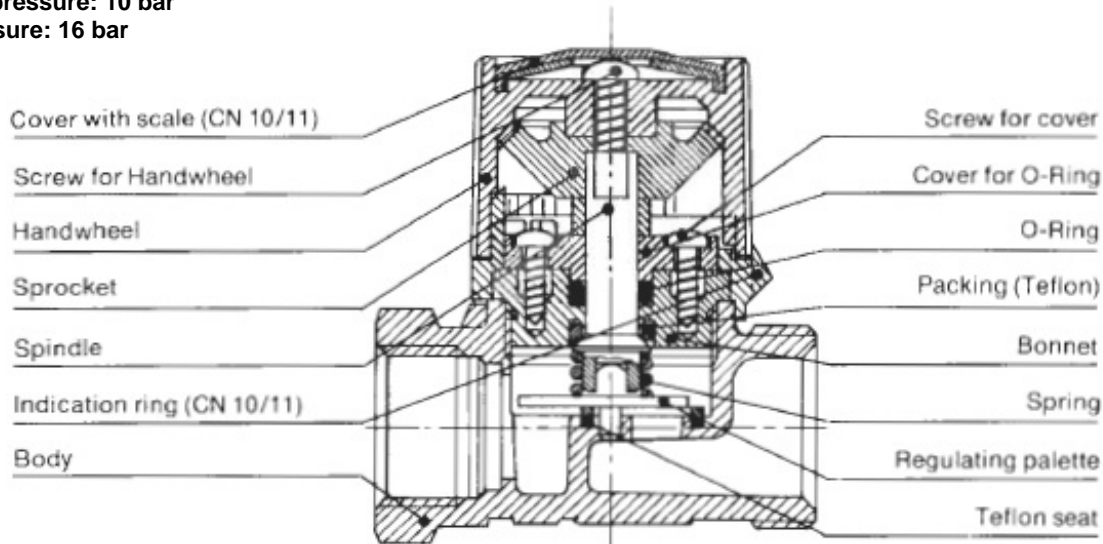

Order No..	Dim.	a mm	b mm	c mm	c1 mm	d mm	e mm	m	n	weight Kg
401220-003	3/8"	50	49	28,5	10	78	12	RG	KRG	0,240
401220-004	1/2"	50	54,5	31	12	86	15	RG	KRG	0,320
401221-004	1/2"	50	54,5	27,5	12	78	15	RG	KRG	0,320
Reserve dele	Tekst									
405920-025	Handwheel complet									
405929-501	O-ring									
V0982005	Rep.kit: O-ring cover/ 2 screws									

J.C.HANSENS METALVAREFABRIK ApS

Karetmagervej 21 | DK-7100 Vejle | Tel. +45 75 85 84 08 | Fax +45 75 85 80 82
 jchansen@jchansen.dk | www.jchansen.dk